Notes on the Chol Dugout Canoe

NICHOLAS A. HOPKINS, J. KATHRYN JOSSERAND, and
AUSENCIO CRUZ GUZMÁN

There is a natural tendency for the modern visitor to the Palenque area to think of access to sites and towns as a matter of roads. Since we travel by car, bus, or truck, we think of places that are not easily reached by road as isolated, cut off from outside contact. What we tend to forget, if indeed it ever occurred to us, is that until very recently roads were almost nonexistent here, and the main routes of passenger and cargo transportation were water routes. Goods and people moved by boat along the extensive waterways that closely connect villages inaccessible by road; thus places we consider marginal and isolated are, in fact, central and well integrated into local networks of interaction.

Increasingly, especially in the last decade, roads and trucks have replaced rivers and boats as the major means of transport. Changes in the population of the Palenque area, with the immigration of nonlocal mestizos on the one hand and of highland Chols on the other, have shifted the cultural focus away from the rivers and toward overland routes and modes of transportation. What we hope to accomplish in this brief presentation is to turn our attention back to the riverine adaptation of the lowland Chols, since this is obviously relevant to understanding the Classic Maya. The area within which navigable streams were probably favored routes, where overland travel is difficult, includes one of the most important subregions of the Classic Maya: from the highlands of Chiapas to the Gulf coast of Tabasco and Campeche on the north, east to the Petén, and southeast of the Chiapas highlands to the Cuchumatanes of Guatemala.

J. E. S. Thompson (1970) has reminded us of the importance of the Postclassic Chontal-managed sea routes around the Yucatán Peninsula and into Central America. Indeed, the name Yucatan is taken from Chontal *yuca t'an*, the native name for the Chontal language, recorded by Columbus in an encounter with Indians in a large trading canoe off the coast of Honduras. Another group of Chontals apparently managed the trade routes up the Usumacinta. The tradition we will discuss here is not Chontal but Chol, and our sources come not from the Usumacinta but from the Tulijá, which drains the valleys between Palenque and the Tzeltal areas of the Chiapas highlands; the Tulijá is a tributary of the Grijalva (before

the Grijalva joins the Usumacinta). But, since in Classic times there was effectively no (linguistic) difference between Chontal and Chol, this should be simply a variety of the same riverine tradition. The information related here comes from Ausencio Cruz Guzmán, who was raised in a Chol-speaking village along the Tulijá, in the municipio of Salto de Agua, west of Palenque. We think of the town of Salto de Agua, the cabecera of its municipio, as isolated and remote, since no transitable road connects it to major highways. Nonetheless, Salto de Agua is an active port, serving not only the Tulijá drainage upstream but also freighters from Villahermosa, which transship goods from the ocean ports to the Mexico City-Mérida railroad, which crosses the Tulijá at Salto de Agua.

With the introduction of roads to most of the Palenque area and with the replacement of lowland Palencano Chols by highland Chols with no particular riverine orientation, boat travel is diminishing but has by no means disappeared. The number of dugout canoes still operating along the rivers is impressive, the master canoe makers still work on their production, and private individuals still make their own canoes for fishing or transport to their milpas. However, one can foresee the day when all cargo will move by truck and only factory-built motor launches will be found on the rivers.

While there is no doubt a considerable amount of ethnographic information on the riverine traditions scattered throughout the literature, there are no in-depth studies; we hope to awaken additional interest in the role of the rivers before this tradition disappears completely. This essay will concentrate on the single-log dugout canoe (Spanish *cayuco*, Chol *hukub*, 'dugout'), its construction, and its use. We are still collecting material on the riverine traditions of the Salto de Agua Chol.

Making a Dugout

A dugout may be made by individuals for their own use, by a group for collective use, or by a maestro and his assistants under contract to a third party. A few years back, all the larger dugouts were commissioned by and made for fincas (large cattle ranches and agricultural establishments), to transport their products downriver and their supplies upriver. Now most dugouts are smaller,

Table 1 The Most Salient Trees for Dugout Construction

Local Spanish Name	Chol Name	Comments
<i>Maca</i> (<i>chontal</i>)	<i>mankohte'</i>	good durability (30 years), the best all-around wood
<i>Cedro</i>	<i>ch'uhte'</i>	good durability but many are hollow, second-best
<i>Caoba</i>	<i>sutz'ul</i>	good durability but many are hollow, and if there are knots the wood will rot around them
<i>Maca blanca</i>	<i>ha'te'</i>	good durability
<i>Laurel</i>	<i>'unte'</i>	good durability
<i>Tinco</i> (= <i>amargoso</i>)	<i>'ik'xi'</i>	good durability, swells in water
<i>Barí</i>	<i>sik balun te'</i>	good durability
<i>Lacté</i>	<i>'ulmo'</i>	not so durable
<i>Caracolillo</i> (= <i>guasibán</i>)	<i>karakol</i>	not so durable
<i>Guanacaste</i>	<i>k'uk' te'</i>	not so durable
<i>Ceibo</i>	<i>yix te'</i>	low durability (2 years), easy to work when green, hardens later

built for individual use. (A large dugout runs to thirteen meters in length and a meter in width; a small dugout, for individual use, runs to about four meters in length.)

When a dugout is to be built, an obvious first step is to locate an appropriate tree and secure whatever permission may be necessary to cut it (from Forestry officials, from the owner of the land, etc.). At least ten species of rainforest trees are considered adequate, all having long, straight trunks without lower branches that might cause knots. The best (i.e., most favored) woods are the longest-lasting, resulting in a dugout that may give as many as thirty years of river service. Ease of working the wood is a secondary consideration, and the location of the tree is almost irrelevant – it is not uncommon to select a tree that is twenty kilometers from the nearest stream. The most salient trees for dugout construction are listed in Table 1, with brief comments (and considerable lacunae in the data); the order of presentation is related to preference, but only in the most general manner.

The tree is felled carefully, so as not to split the wood. First cuts (called *camas* in Spanish and *pam* in Chol) are placed to control splitting and the direction of fall of the tree. Since these are rainforest species, they often have buttress roots, and a platform must be built so that the trunk can be cut above the buttresses.

After felling, the trunk is examined for defects; knots and hollows are sounded with rods to determine their extent. The maestro then decides how the log is to be cut to insure maximum use in relation to the defects present. Major sections to be cut away are not lost but are made into troughs and other artifacts. (It is interesting to note that, in local Spanish, the troughs used for feeding

and watering animals, as well as for washing clothes, are called *canoas* or *bateas*, both terms related to types of canoes.)

The felled trunk is cut to length, the root end and the too small upper sections where branching begins are taken off, and the log is then laid out as the maestro directs. The maestro cuts deep grooves across the log, near each end, to the level at which he wants the wood to be cut away (Fig. 1a). He levels these transverse cuts, squares them perpendicular to the length of the log, and then runs a string from the base of the grooves along each side of the log. The wood will be cut away down to this mark (Fig. 1b, c). Cutting is done with axes; some trimming (especially on the ends) is done with a machete; and two kinds of adzes are used for finish work. The adzes have a flat cutting blade (Spanish *suela* or *plana*) or a curved cutting blade (*gurbia*); they are used mainly for finish work on inside surfaces.

Lines are now drawn to indicate how the outside curves of the sides will be cut. A series of marks are drawn at right angles to the trunk, at regular intervals, using a carpenter's square (Fig. 1d). The width of the log at these marks is measured, and nails are tapped into the wood at the appropriate points to give a slight mid-to-end taper to the log. The ends may be different widths, and midships-to-stern or midships-to-bow symmetry is not a concern. A string is loosely laid along the line of nails, and contours are penciled in along the string. Both inside and outside contours are marked, about an inch apart at their closest.

A centerline is marked with string, special attention being given to the ends of the log, where the stern and bow will be shaped. The outside curves of bow and stern are drawn in, centered along this line. A more traditional technique for drawing these curves involves using a large leaf, folded and cut to the contour of one side; it is unfolded to give the contour of the other side, insuring symmetry. A more modern technique involves the use of plastic yardsticks, which can be bent to the desired curve. At any rate symmetry around the centerline, in bow and stern cuts, is mainly for aesthetics and not for performance. The canoe ends are shaped by the maestro, using a machete according to the lines traced.

The sides of the log are now cut away with axes, working from amidships toward the ends, so as not to split the wood along the grain. For the time being, the outside contours are cut straight down, perpendicular to the ground, and not tapered toward the bottom of the dugout. (Judging from photographs of some Lacandón jungle dugouts, the sides may be left this way and not tapered.)

The inside contour is now cut out. The maestro makes a series of cuts to mark the depth of hollowing and the angle to be given to the sides. The inside opening of the dugout will be narrower at the bottom and wider at the top. The assistants cut away the wood to the contours indicated. The hollowing is done with an ax but will be finished later with curved and plane adzes.

After the log has been cut down to the proper height of the gunwales, the outside contours have been cut

square, the interior has been hollowed out, and the bow and stern contours have been cut (Fig. 1e), the log is turned so that the bottom may be shaped and the outsides may be sloped in to the proper angle. Before the log is turned, three sets of one-inch holes are drilled through the bottom of the dugout: three holes in a line across each end and three in a line across the middle of the interior bottom of the hollowed-out log. These will be used to set the thickness of the bottom.

A stand, made of poles, is set up to receive the log as it is turned (Fig. 1f). A pole is tied across the thwarts, flush to the near side of the dugout and extending from the far side for a couple of meters. This pole will be used as a lever to turn the heavy log. Vines are the traditional tying materials.

A winch is made opposite the log, across the receiving platform. The winch consists of two sets of poles, each set bound together with vines in the middle. A pole is laid between these pairs of poles, between the vine ties, to serve as the axle of the winch. A vine is wound on the axle and tied to the lever lashed to the thwarts. Another pole is used as a lever to turn the winch. The log is winched up and over onto the receiving platform.

Once on its stand, the log is again leveled; blocks and wedges are used to hold it in its proper position. The holes drilled through the hull are consulted to set the thickness of the bottom. The maestro makes guide cuts to indicate the proper thickness, and the assistants cut away the bottom to his marks. The bottom is cut flat, perpendicular to the sides of the dugout at this time. The maestro also cuts guide wedges along the sides to indicate the slope to which the sides are to be trimmed, leaving the wood slightly thicker toward the bottom of the dugout and slightly thinner along the gunwales (Fig. 1g). Again, the assistants follow the maestro's guide cuts to remove the excess wood.

The holes through the hull are now plugged, using wood from the same tree. (Knots and splits are plugged in the same way.) Finishing touches include a line of holes drilled along each side, just under the gunwales (Fig. 1h). These will be used to tie poles or lengths of cane across the dugout to cover cargo space, to attach oarlocks, and so on.

The construction of a dugout, from felling the tree to finishing the final details, normally takes about two weeks in the case of a large dugout built by a maestro and some six assistants. When the dugout is finished, a meal is organized in which the maestro and all his assistants participate. This ceremonial meal may be sponsored and organized by the owner of the new canoe or, in his default, by the maestro himself. The dugout is then transported to the nearest stream; this may be undertaken as part of the same contract by the maestro or as an independent job arranged by the owner.

Transport is effected by tying poles across the body of the dugout, using the holes drilled along the sides. On either side of the dugout, at either end of the poles, a man takes a position. The number of poles and pairs of men depends on the size of the canoe. Another man takes a position at the rear of the dugout to guide it. The

dugout is then slid along on small logs and poles laid under it transversely. In brush, men go ahead cutting and trimming branches and poles to be placed under the dugout; others move forward to carry the poles that have been passed over, to reposition them. One case has been reported to us in which thirty men took four days to transport a twelve-meter canoe to the nearest water. When the dugout is launched, a celebration is organized by the new owner. As many people as possible pile into the canoe to test its carrying capacity.

Using the Dugout

The crew that manages a large cargo canoe is headed by a *patrón* (not the owner, necessarily, but a professional canoe master) and includes his *bogas* (oarsmen). The *patrón* stands at the rear, facing forward, and guides the dugout with a long, wide oar, which he rests on the gunwales near the stern in wedge-shaped cuts made for this purpose. The *bogas*, sitting in front of him on alternating sides on sacks of cargo, face backward and row with oars placed in oarlocks. The oarlocks are made of forked sticks tied to transverse poles secured by vines to the holes drilled along the sides. The *bogas'* oars (in local Spanish, *remos de tira*) are two and a half to three meters in length; the *patrón's* long oar (*remo largo*) is about four meters long. The technique of rowing is probably a European introduction, as the Classic depictions that we are aware of show dugouts being paddled rather than rowed. Indeed, except for the large cargo canoes, dugouts today are usually paddled by a man or men standing upright.

The cargo carried can be virtually anything. Cargo in bundles or sacks is stacked in the bottom of the dugout and serves as seats for the oarsmen. Poles tied across the thwarts form a framework for cane coverings that create closed compartments for transporting such small livestock as pigs and chickens. Large dugouts can carry cattle and other large livestock. Payloads run up to three thousand kilos on a downstream run, half that on an upstream run, when the dugout may have to be towed from the bank in strong currents.

A downstream run on the Tulijá from Agua Clara, just below the falls at Agua Azul, to Paso Naranjo, just above the falls at Salto de Agua, takes about twelve hours. Cruz' father worked as a canoe master on this run for several years, contracted to the fincas to bring down chicle. On the return trips, which took about three days, he carried merchandise, food, and other supplies for the *chicleros*. The fincas supplied the dugouts and paid the *patrón* and the *bogas* by the day.

Dugouts are also used for fishing, either sporadically or as a more or less systematic complement to agricultural production. Besides numerous varieties of fish (for which we are collecting extensive Chol terminology), turtles, alligators, and freshwater lobsters (local Spanish *pigua*) are exploited for food and other uses. Some villages fish more than others, which in turn are more agricultural. Fish is sometimes traded for agricultural products; for example, a fisherman may trade a few fish for tortillas, roasted ears of corn, chiles, or bananas to complete his meal.

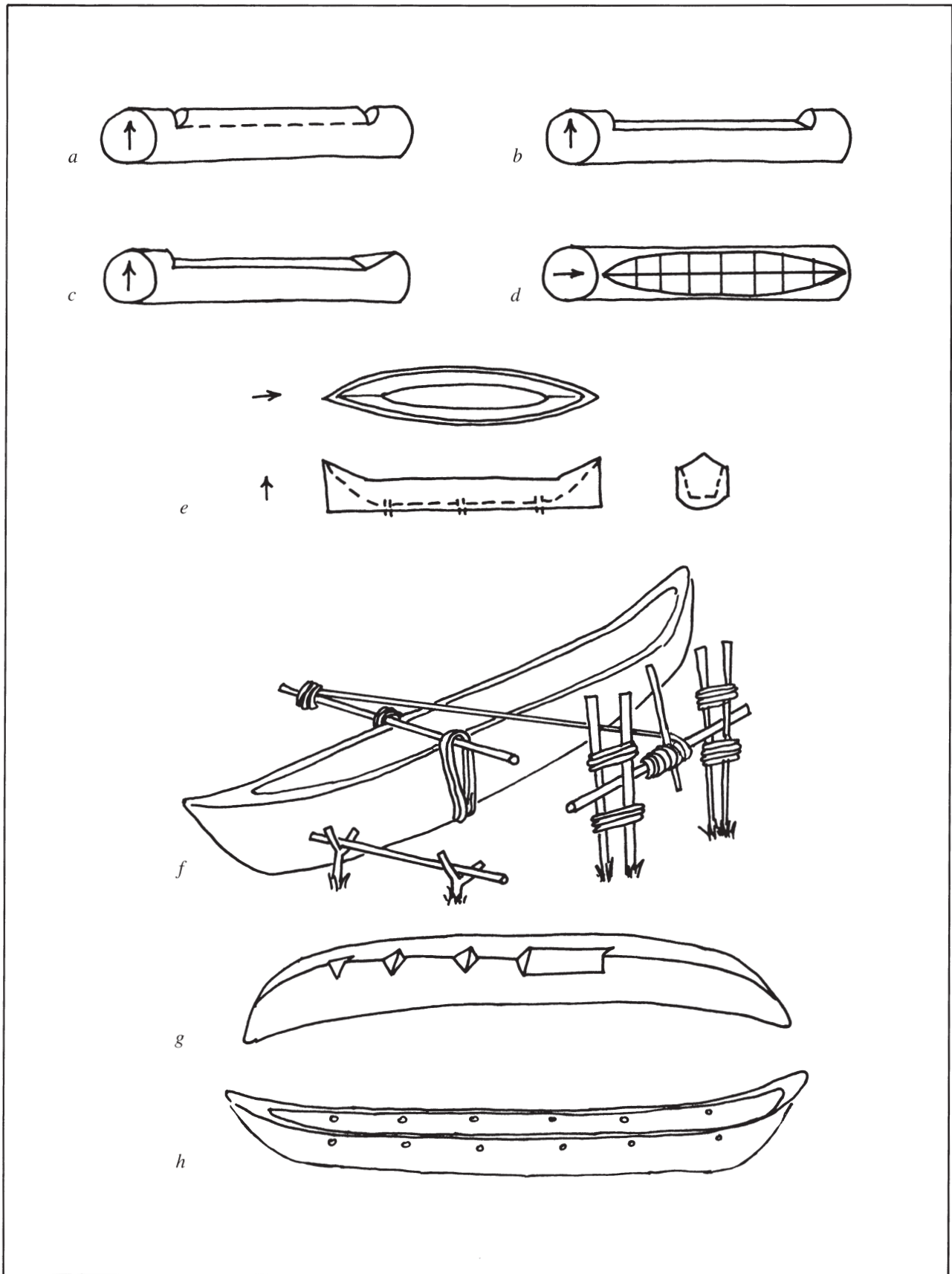

Fig. 1 Stages in the making of a dugout canoe.

Other Lore

Dugouts are more than a means of transport for people, animals, and goods, more than vehicles for fishing and hunting turtles. They are not just economic devices. Dugout canoes play a role in mythology: we have recorded a story about three fishermen in a dugout who encounter Lightning (*lak mam*, 'our grandfather') and his wife, a huge toad (*lah ko*, 'our grandmother'), as Lightning is gathering wild plant food along the banks of the river. Dugouts are involved in family feuds: we have been told a tale of a rancher and his son whose rivalry was played out in a competition to build the largest and most elegant dugout and to name the dugouts in the most antagonistic way. Countless stories are told and retold about incidents

of river travel, in which dugouts, canoe makers, canoe masters, the rivers, and their peculiarities figure prominently. Other kinds of vessels also occur in the riverine culture of the lowland Chol: rafts are made, and we have been told of three-log canoes over two meters in width.

This technology and its associated lore form a rich source of Maya ethnographic information that we are only beginning to record. We hope that this essay will call attention to a much neglected area whose investigation would go a long way toward balancing our knowledge of Mayan cultures, now known almost exclusively from the highlands or from agriculturally oriented lowland areas.